

(No Model.)

9 Sheets—Sheet 1.

L. G. MERRITT.
LATHE FOR TURNING IRREGULAR FORMS.

No. 536,385.

Patented Mar. 26, 1895.

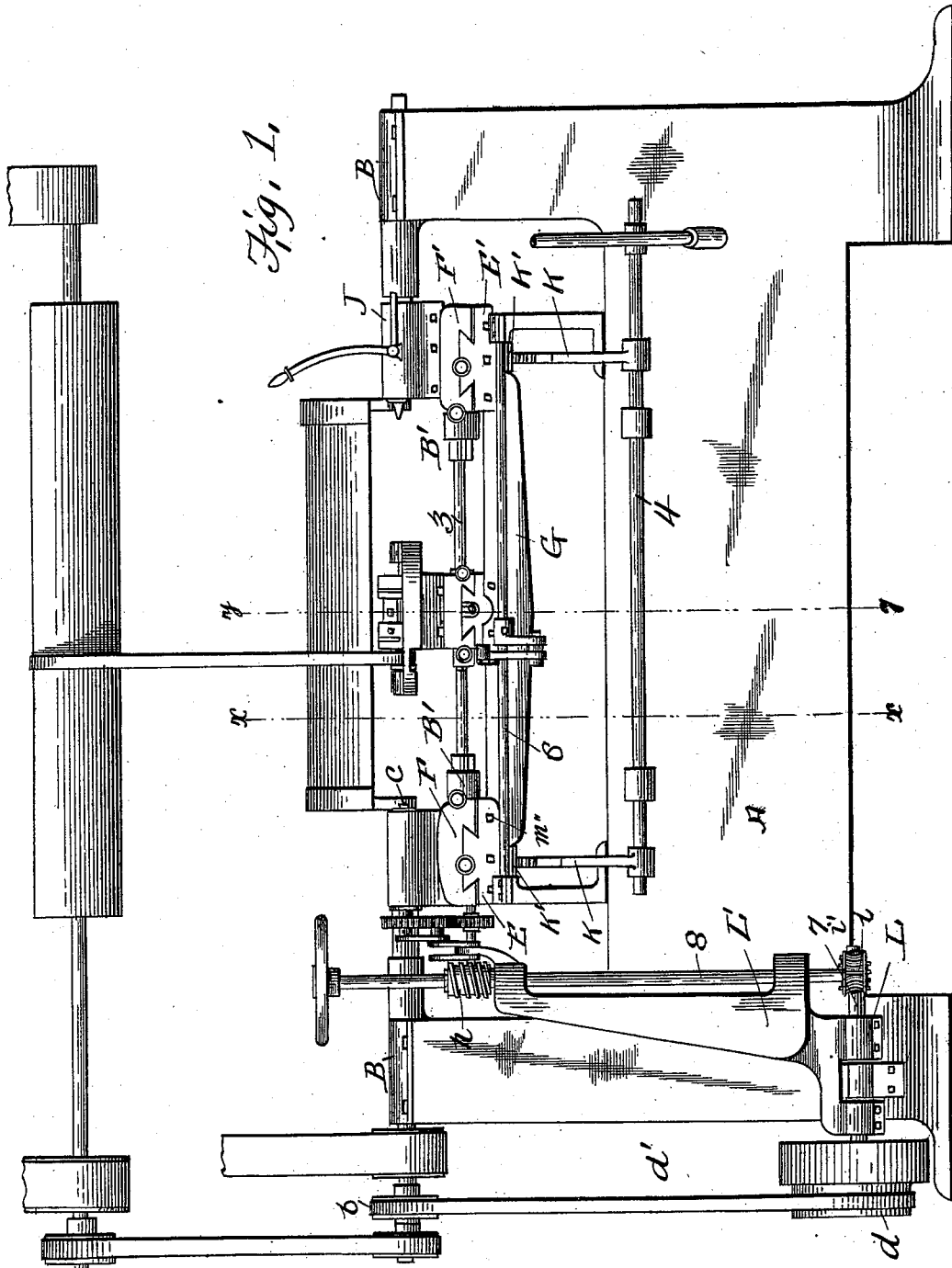

Fig. 1.

WITNESSES

T. W. Johnson,
Mark W. Dewey

INVENTOR

Louis G. Merritt
By *C. H. Druell*
his Attorney.

(No Model.)

9 Sheets—Sheet 2.

L. G. MERRITT.
LATHE FOR TURNING IRREGULAR FORMS.

No. 536,385.

Patented Mar. 26, 1895.

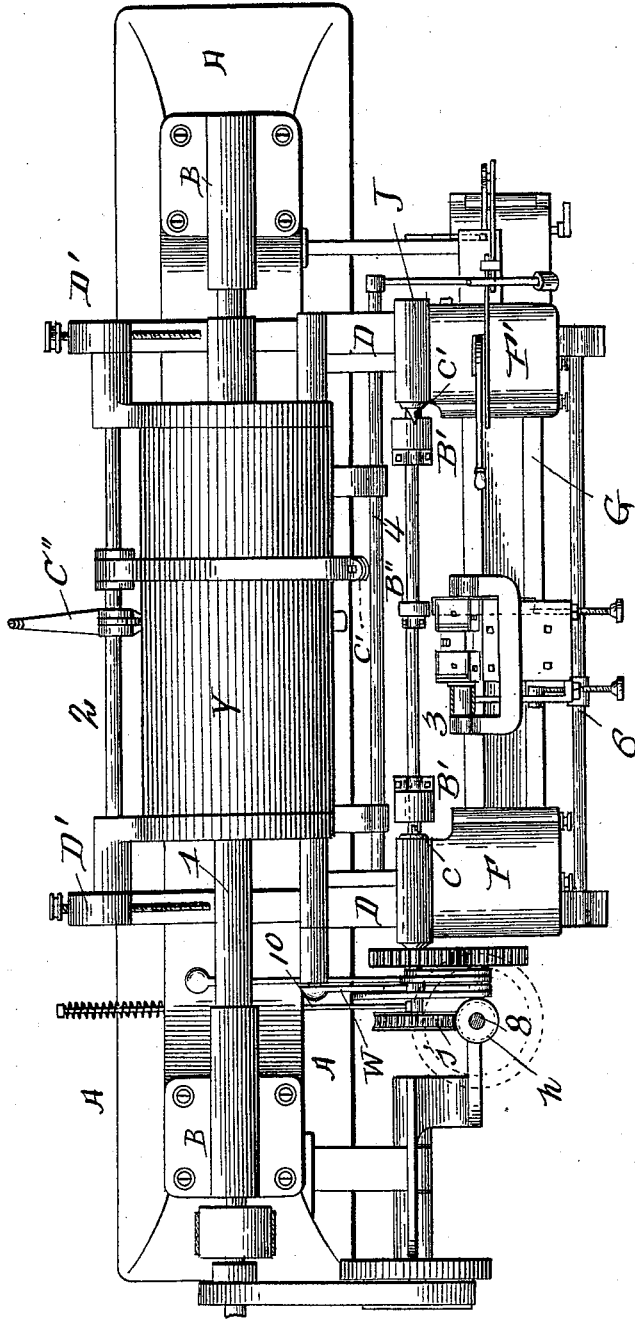

Fig. 2.

WITNESSES-

S. W. Johnson
Mark W. Dewey

INVENTOR

Louis G. Merritt
By *C. H. Bruce*
his Attorney

(No Model.)

9 Sheets—Sheet 3.

L. G. MERRITT.
LATHE FOR TURNING IRREGULAR FORMS.

No. 536,385.

Patented Mar. 26, 1895.

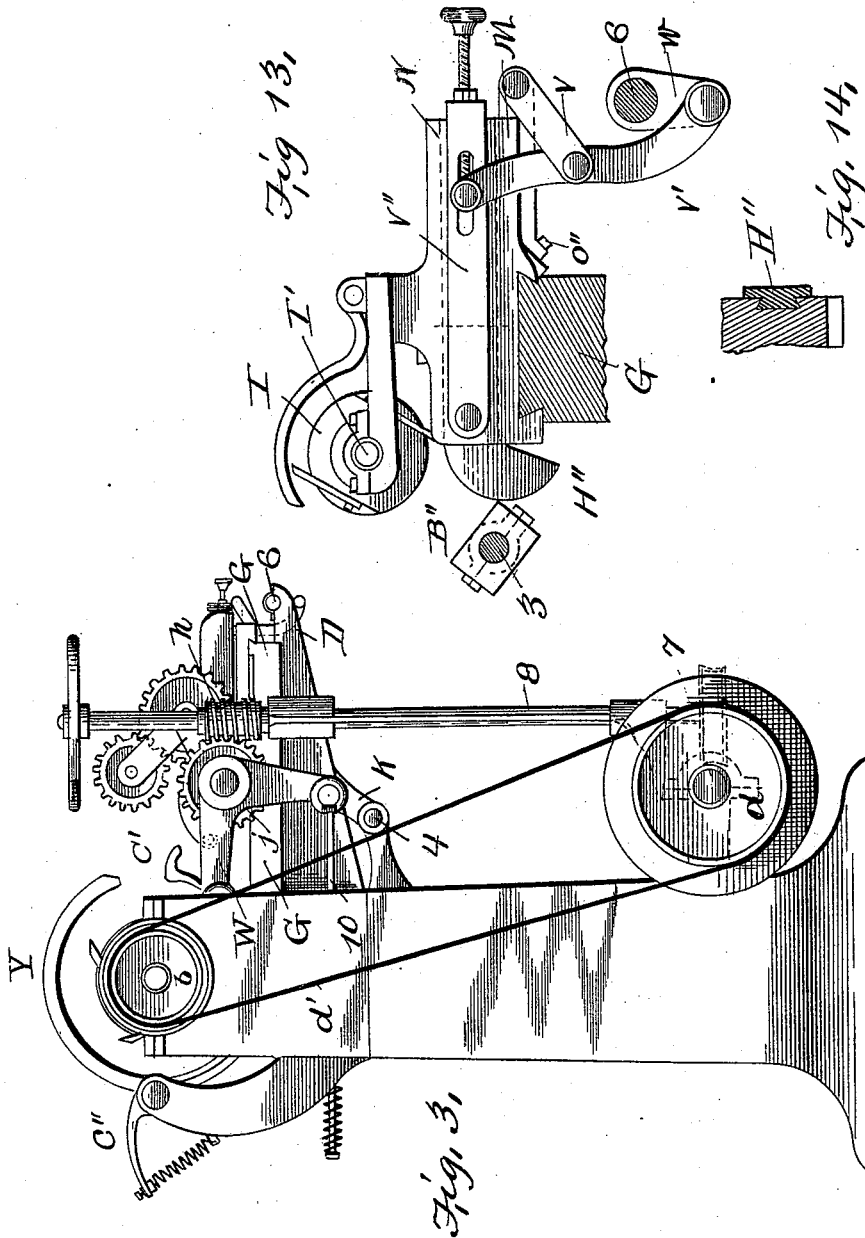

WITNESSES:

T. W. Johnson.
Mark W. Dewey.

INVENTOR,

Louis G. Merritt
By *C. H. Druell*
his Attorney.

L. G. MERRITT.
LATHE FOR TURNING IRREGULAR FORMS.

No. 536,385.

Patented Mar. 26, 1895.

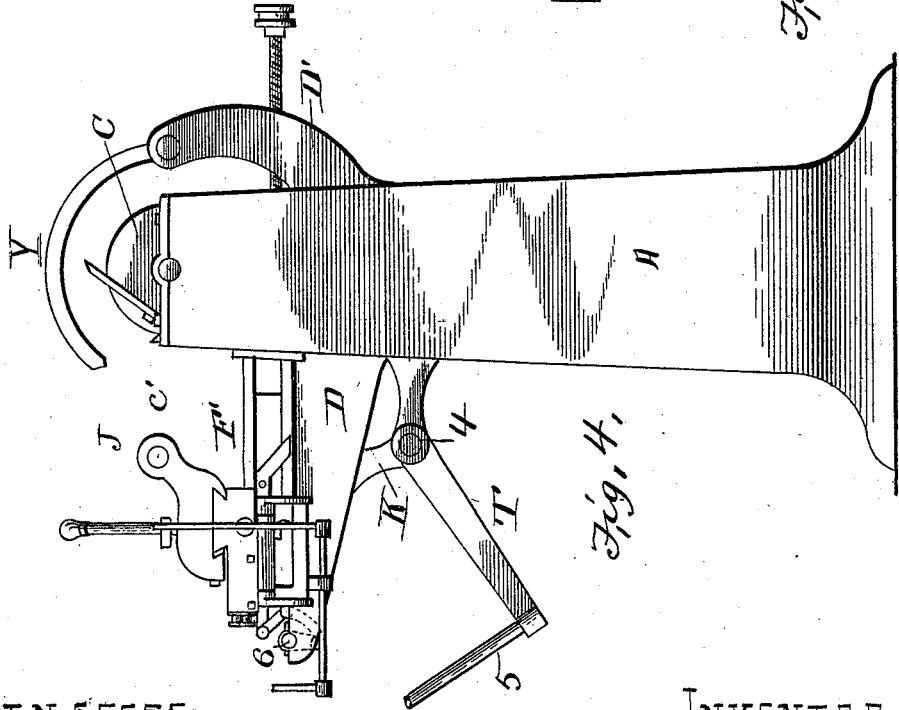
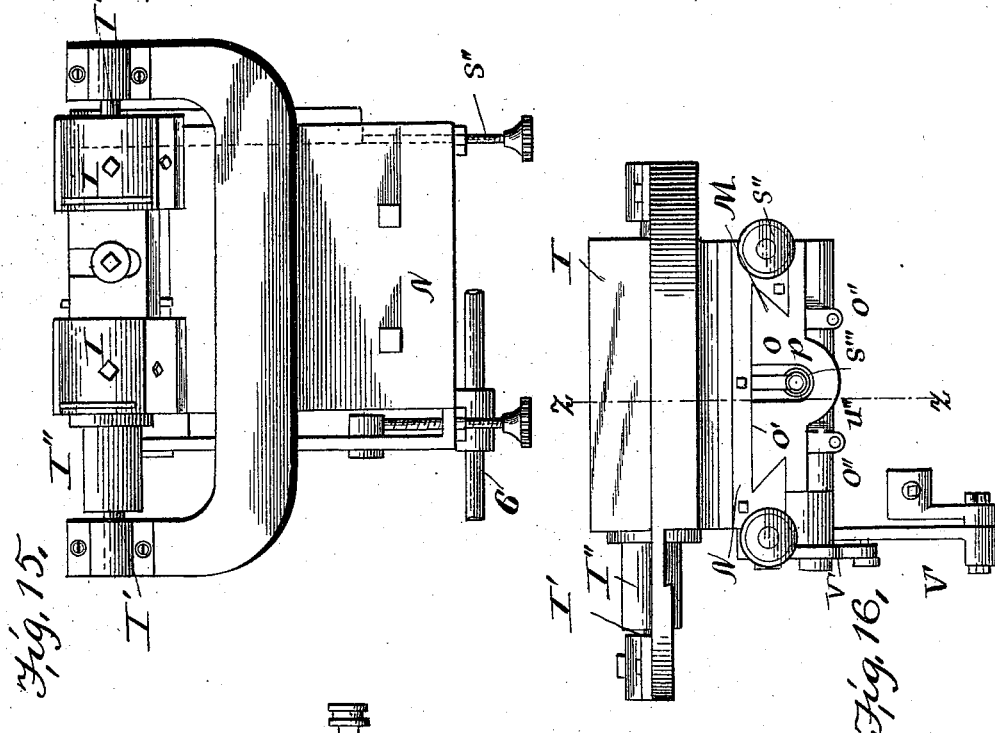

WITNESSES:
L. W. Johnson,
Mark W. Dewey

INVENTOR
Louis G. Merritt
 By *C. H. Druce*
his Attorney

(No Model.)

9 Sheets—Sheet 6.

L. G. MERRITT.
LATHE FOR TURNING IRREGULAR FORMS.

No. 536,385.

Patented Mar. 26, 1895.

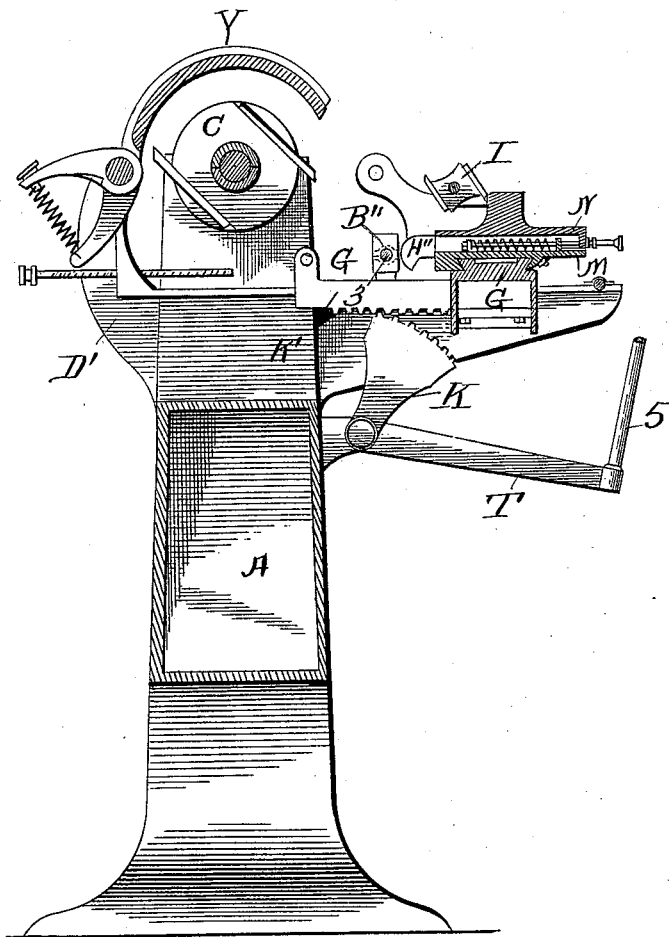

Fig. 6.

WITNESSES

T. W. Johnson,
Mark W. Dewey

INVENTOR

Louis G. Merritt
By C. H. Duell
his Attorney.

(No Model.)

9 Sheets—Sheet 7.

L. G. MERRITT.
LATHE FOR TURNING IRREGULAR FORMS.

No. 536,385.

Patented Mar. 26, 1895.

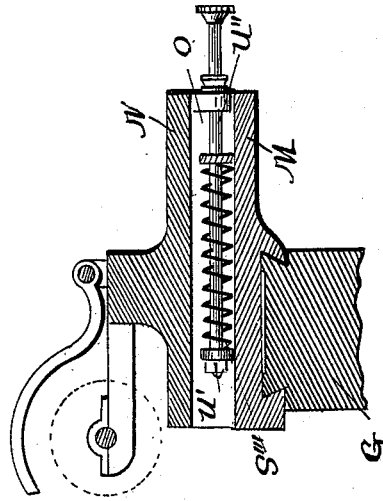

Fig. 8.

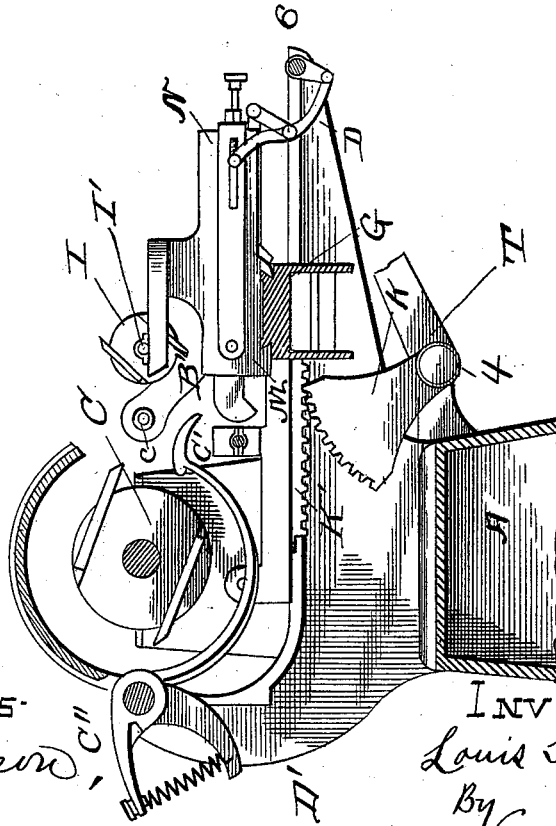

Fig. 7.

WITNESSES:

T. W. Johnson,
Mark W. Dewey

INVENTOR
Louis G. Merritt
By *C. H. Druell*
his Attorney.

L. G. MERRITT.
LATHE FOR TURNING IRREGULAR FORMS.

No. 536,385.

Patented Mar. 26, 1895.

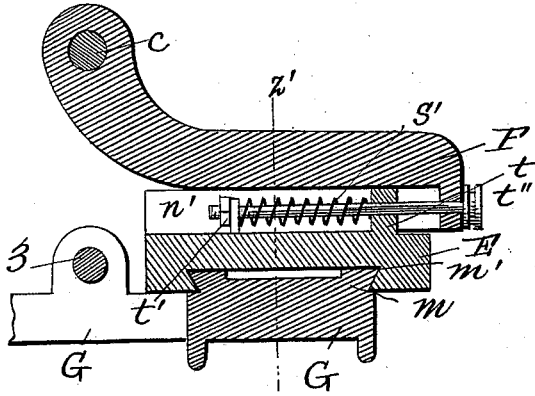

Fig. 9,

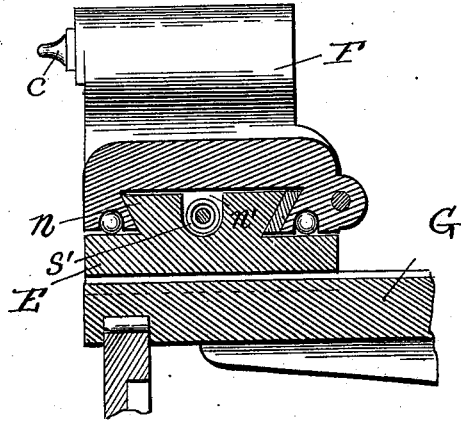

Fig 10,

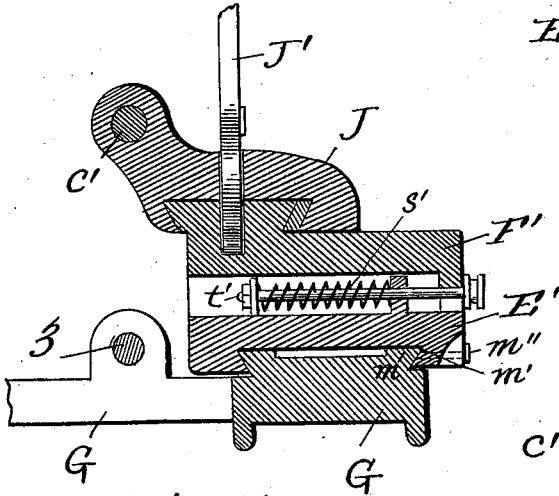

Fig. 11,

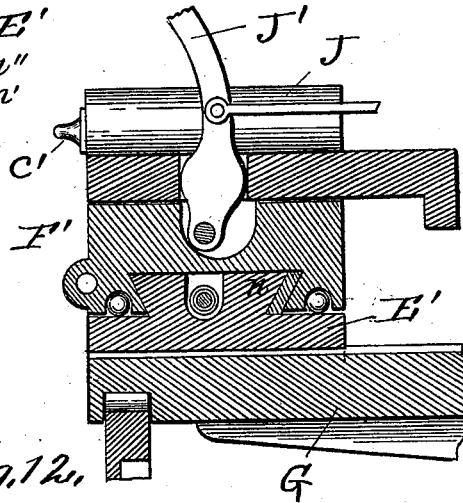

Fig. 12,

WITNESSES-
J. W. Johnson,
Mark W. Dewey

INVENTOR
Louis G. Merritt
By C. H. Duell
his Attorney.

(No Model.)

9 Sheets—Sheet 9.

L. G. MERRITT.
LATHE FOR TURNING IRREGULAR FORMS.

No. 536,385.

Patented Mar. 26, 1895.

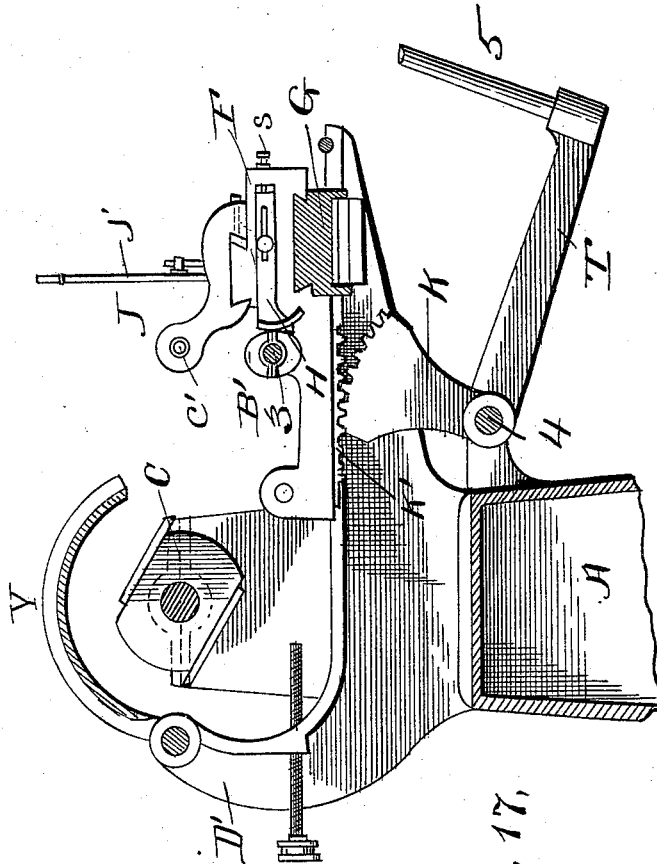

Fig. 17.

WITNESSES

G. W. Johnson,
Mark W. Dewey

INVENTOR

Louis G. Merritt,
By C. H. Duell
his Attorney

UNITED STATES PATENT OFFICE.

LOUIS G. MERRITT, OF LOCKPORT, NEW YORK.

LATHE FOR TURNING IRREGULAR FORMS.

SPECIFICATION forming part of Letters Patent No. 536,385, dated March 26, 1895.

Application filed June 26, 1894. Serial No. 515,778. (No model.)

To all whom it may concern:

Be it known that I, LOUIS G. MERRITT, of Lockport, in the county of Niagara, in the State of New York, have invented new and useful Improvements in Lathes for Turning Irregular Forms, of which the following, taken in connection with the accompanying drawings, is a full, clear, and exact description.

My invention relates to certain new and useful improvements in lathes for cutting spokes and other irregular forms; and the object is to provide means, with a lathe similar to or the same as that shown and described in United States Patent No. 504,812, dated September 12, 1893, whereby one or both ends, or one or more intermediate parts, or both, of a stick may be cut square or to any other desired form simultaneously with the cutting of another part of the stick to another form, so that, for instance, when cutting spokes, it will not be necessary to form the spoke by subjecting it to a second operation in order to square one end, for one and the same lathe performs both operations simultaneously, saving much time and labor.

To this end my invention consists in providing a lathe with a supplementary cutting attachment so constructed and arranged that it will have a reciprocating rectilinear motion toward and from the main cutter-head without interfering with the operation of the other parts of the lathe.

In the drawings hereto annexed, Figure 1 is a front elevation of a lathe embodying my invention. Fig. 2 is a plan view of the same. Figs. 3 and 4 are views of opposite ends of the lathe. Figs. 5 and 6 are vertical transverse sections on lines x, x , and y, y , respectively, in Fig. 1. Fig. 7 is a sectional view corresponding with Fig. 5 but showing the machine in its operative position. Fig. 8 is an enlarged vertical transverse section on line z, z , of Fig. 16. Fig. 9 is an enlarged transverse section of the feed table with the head-block mounted thereon. Fig. 10 is a transverse section on line z', z' , in Fig. 9. Figs. 11 and 12 are sectional views of the tail-block. Fig. 13 is an enlarged side elevation of the attachment. Fig. 14 is a sectional view of the shoe bar. Fig. 15 is a top plan view of the

attachment. Fig. 16 is the front side view of the same, and Fig. 17 is an enlarged transverse section of Fig. 1.

Similar letters and figures of reference indicate corresponding parts.

Referring specifically to the drawings, A represents the main supporting frame of the lathe provided at opposite ends of its top with bearings, B, B, for the arbor 1 on which are mounted the cutter-heads, C, equipped with cutters of the requisite shape.

D, D are horizontal ways firmly secured to the frame, A, and disposed at right angles to the cutter arbor, 1, and are formed with rearwardly and upwardly curved extensions, D', to the free ends of which is rigidly secured a horizontal shaft, 2, which carries the shield, Y, extending over the main cutter-heads C. On the same shaft is loosely mounted the rest, C', which extends under the said cutter-heads and in front of the same to support from underneath the work which is operated upon by the cutters as is well known and therefore not necessary to be herein more fully described. The same applies also to the upper rest, C'', shown in the drawings.

Upon the ways, D, D, is mounted the table, G, which is formed with horizontal extensions directly over the ways and parallel therewith to serve as bearings on said ways and support the table which carries the work together with the revolving cams to the main cutters and supports the work while operated on without subjecting said work to the weight of the table. The said table rides on the said ways, D, D, back and forth, the movement being imparted to the table by suitable well known mechanism operated by the person in charge of the machine. The top of the table is formed with a longitudinal guide, m , which is parallel with the axis of the lathe and dove-tail shaped in cross-section and upon this guide are mounted adjustably the vibratory or reciprocating head-block and tail-block upon which is centered the stick to be operated on by the cutters of the cutter-heads.

The head-block consists of two parts, viz: a base, E, and block, F. Said base is provided in its underside with a dove-tail groove, m' , by which it is seated on the guide, m , of the table

and is fastened thereto by means of a set-screw, *m''*, passing through the front portion of the base, *E*, and engaging the table *G*. The top of the base, *E*, is formed with a transverse dove-tail tongue, *n*, and upon said base rides the vibratory block, *F*, provided with a dove-tail groove through which the tongue, *n*, passes and guides said block rectilinearly toward and from the cutters. The block, *F*, is provided with the driving center, *c*, which engages one end of the stick to be operated on by the cutters, and in order to cause said cutters to impart a polygonal shape to said end of the stick, the block, *F*, is made to vibrate automatically toward and from the cutters by means of a suitable cam, *B'*, which is of the shape to be imparted to the head end of the stick and is secured to a rotary shaft, *3*, mounted on the table and extending lengthwise thereof, said shaft receiving motion as hereinafter described. The cam, *B'*, engages a shoe, *H*, which is adjustably secured to the block, *F*, by a screw passing through a longitudinal slot in the shoe so as to allow said shoe to be set different distances from the axis of the cam and thus vary the thrust of the block, *F*, according to the depth of cutting to be effected on the work or stick. A set-screw, *s*, connected to the block, *F*, and bearing on the outer end of the shoe, securely retains the same in position. A suitable spring, *s'*, interposed between the base, *E*, and block, *F*, forces the latter toward the cutter-heads, *C*, and thus maintains the shoe in contact with the cam *B'*. In order to house and protect said spring and also allow the tension thereof to be adjusted, I provide the top of the tongue, *n*, with a longitudinal groove, *n'*, to accommodate the spiral spring, *s'*, which bears with one end upon the lug, *t*, projecting from the base, *E*, and with the opposite end upon a nut, *t'*, connected to an adjusting screw, *t''*, which passes freely through the front or outer end of the block, *F*, and is shouldered on the exterior thereof.

The tail-block which carries the dead-spindle, *c'*, of the machine is composed of three main parts, viz: the base, *E'*, vibrating block, *F'*, and tail center block *J*. The base is similar to the base of the head-block and mounted in the same way upon the table *G*. The vibrating block, *F'*, is mounted on the base, *E'*, in the same manner as the block, *F*, hereinbefore described, and the block, *J*, which carries the tail center, *c'*, is mounted on the block, *F'*, movably in a line parallel with the axis of the lathe and is guided by a dove-tail tongue, *q* on top of the vibrating block, *F'*, entering a corresponding groove in the under side of the block *J*.

The vibrating block, *F'*, of the tail-block receives motion in the same manner as the vibrating block of the head block; *i. e.*, by a cam, *B'*, mounted on the shaft, *3*, and shaped to correspond to the shape to be imparted to the tail end of the stick held between the two centers *c* and *c'*. Said cam operates against

a shoe, *H*, attached to the block, *F'*, in the same manner as hereinbefore described in relation to the head-block.

It will be observed that by the described arrangement of the vibrating head and tail centers with separate cams for operating them independently of each other and without imparting a corresponding motion to the table, I am enabled to produce a greater variety of shapes on sticks operated on by the cutters. The block, *F'*, is forced toward the head-block by means of a tension spring, not shown, connected to the block, *F'*, and to a collar on an arm extending from the block *J*.

To the block, *F'*, is pivoted the hand lever, *J'*, by means of which the block, *J*, is retracted to allow the work to be introduced between the two centers of the lathe.

In drawing the table, *G*, to the front the motion of the head-center and cam-shaft, *3*, is automatically arrested and thus the work is readily introduced between the centers.

The cams, *B'*, I prefer to form each of two parts embracing one-half of the circumference of the shaft and provided with perforated ears for the reception of screws or bolts by which they are clamped on the shaft, said construction permitting a ready attachment and detachment of the cams and facilitating the application of cams of different shapes.

For moving the table, *G*, toward and from the cutter-heads, I prefer to employ segmental gears, *K*, *K*, fixed to a horizontal shaft, *4*, extending lengthwise of the frame, *A*, and mounted in suitable bearings thereon, said gears engaging racks, *K'*, *K'*, fastened to the table, and by means of a suitable handle or lever, *5*, attached to an arm, *T*, which is fastened to shaft, *4*, the person in charge of the machine imparts oscillatory motion to the gears, *K*, *K*, which transmit motion to the table by means of the aforesaid racks. A set screw adjustably connected to the frame in the path of the table limits the movement of the latter toward the said cutters.

Suitable and well known means may be employed with the above described lathe for accurately feeding fine work to the cutters and for centering the work when it is inserted between the centers.

The arbor, *1*, cam-shaft, *3*, and head-center, *c*, receive motion by the following means: To the arbor, *1*, is attached the driving pulley, *a*, which is connected by a belt with a suitable motor not shown. To the base of the frame, *A*, is firmly secured a horizontal journal-box, *L*, through which passes a counter shaft, *7*, to the outer end of which is fastened the cone pulley, *d*, which is connected by a belt, *d'*, with a smaller cone pulley, *b*, attached to the end of the arbor *1*. The ends of the journal-box, *L*, are formed with tubular trunnions on which is mounted the standard, *L'*, which is thus permitted to swing in a vertical plane with its upper end toward and from the arbor. In bearings on opposite ends of the standard, *L'*,

is journaled a vertical shaft, 8, to the lower end of which is affixed a worm wheel, *i*, engaging a worm, *i'*, fastened to the horizontal shaft, 7. To the upper end of the vertical shaft, 8, is attached a worm, *h*, which, in swinging the standard, *L'*, back and forth, is adapted to engage and release a worm wheel, *j*, attached to the cam-shaft 3. They are held in engagement by means of a bell crank lever, *W*, pivoted at the junctions of its arms to the crank-shaft, 3, and connected to the upper end of the standard by a curved link pivoted to the horizontal arm of the lever, *W*, and to the standard, as shown. The free end of the horizontal arm of said lever is weighted to draw the standard, *L'*, toward the frame, *A*, and thus hold the worm, *h*, in engagement with the worm-wheel *j*. As the table, *G*, is drawn forward or from the said cutters, the rod, 10, is caused to exert a greater pull on the vertical arm of the lever, *W*, and tends to turn said lever so as to lift the horizontal arm thereof and cause the same to throw the worm, *h*, out of gear by means of the link.

The above is a brief description of the lathe hereinbefore referred to, and well known, to which my improved attachment may be readily and easily applied, the description being given in order that the working of said attachment hereinafter described may be more fully understood in connection with the lathe to which it is applied. However, although this description might be continued, it is thought that the old construction has been sufficiently set forth, and I will now proceed to describe the attachment.

It is the supplementary cutter-head which has preferably a smaller diameter than the main cutter head, *C*, and is shown arranged with its axis parallel to the axis of the main cutter-head although it may be set at any angle to the latter if desired. This cutter-head is mounted upon a block constructed the same or similar to the head-block above described, that is, it consists of two parts, viz: a base, *M*, and a block *N*. Said base is provided in its under side with a dove-tail groove, *o'*, by which it is seated on the guide, *o*, of the table, *G*, and is fastened thereto by means of a set-screw or screw, *o''*, passing through the front portion of the base and engaging the table *G*. The top of the base, *M*, is formed with a transverse dove-tail tongue, *p*, and upon said base rides the reciprocating or sliding block, *N*, provided with a dove-tail groove through which the tongue, *p*, passes and thus guides said block rectilinearly toward and from the cutters. The block, *N*, is provided with an arbor, *I'*, carrying the supplementary cutter-head, *I*, and a small pulley *l''*. The said pulley is connected by a belt with a long drum on a counter-shaft overhead and this counter-shaft is operated by any suitable means, but preferably by a belt connecting a pulley thereon with a pulley on the end of the arbor, *l*, of the lathe as shown in Fig. 1 of the drawings.

The sliding cutter-block is reciprocated automatically to impart the desired shape to the end or other part of the stick by means of a suitable cam, *B''*, which is of the shape to be imparted to that end or part of the stick operated upon by the small cutter, but said cam has a throw equal to the difference between the long and short radii of the shape to be turned plus the throw of the cam or cams governing the shape of the body of the work or stick. This cam is shown square in the drawings, but may be oval or otherwise shaped according to the work to be done, and is made preferably in two parts as the other cams hereinbefore referred to, to facilitate removal from or lengthwise of the shaft when the small cutter-head is shifted.

The cam, *B''*, engages a shoe, *H''*, the same or similar to the shoes of the head and tail blocks, but is preferably provided with a tongue on its inner side entering a dove-tail groove in the side of the said block, *N*, as shown in Fig. 14 of the drawings.

A set-screw, *s''*, connected to the block, *N*, and bearing on the outer end of the shoe securely retains the same in position. A suitable spring, *s'''*, interposed between the base *M* and block, *N*, forces the latter toward the main cutter heads and thus maintains the shoe in contact with the cam, *B''*. This spring is housed in the same manner as the spring on the head-block above referred to, and bears with one end upon a lug, *u*, projecting from the base, *M*, and with the opposite end on a nut, *u'*, connected to an adjusting screw, *u''*, which passes freely through the front or outer end of the block, *N*, and is shouldered on the exterior thereof.

In order to move the block, *N*, with its cutter-head, *I*, farther from the main cutter-heads than the table, *G*, is moved by means of the lever, *5*, and arm, *T*, so that the parts of the apparatus will in no wise interfere with the removal from and insertion of work in the lathe, *I* provide a system of levers between and connected with the stationary shaft, 6, and the sliding or reciprocating-block *N*. One of the said levers, *v*, is connected with or pivoted to the base, *M*, that moves with and is rigidly secured to the table, *G*, one end of said lever being pivoted, intermediate of its length, to a lever, *v'*, extending upwardly and rearwardly from a depending support, *w*, fixed to the shaft 6. The upper end of the lever, *v'*, is pivoted in a slot in a horizontal lever, *v''*, pivoted at its rear end to the side of the block, *N*, and having an adjusting screw, *x*, passing through its front end and bearing upon the lever, *v'*, to regulate the movement of the block. By this system of levers the work when completed is not only withdrawn from the main cutters, *C*, but the supplementary cutters, *I*, are simultaneously withdrawn from the work leaving it perfectly free to be removed without injury to the work or the operator.

The small shaping head is not confined to one end of the work, but may be set anywhere along its length together with its operating cam, B'.

5 It will be obvious that more than one supplementary shaper may be employed and brought to act simultaneously on the work.

The supplementary heads are made small because the shoe must have the same circumference and the smaller it is the more evenly it follows the cam, and especially a square one.

10 The operation of the machine is as follows: The arbors to which the cutter-heads C and I are attached are rotated at a high rate of speed while the driving center and cam-shaft, 3, receives a slow and synchronous motion. The table, G, is drawn away from the main cutters, C, and in this movement the cam-shaft, 3, and driving center are stopped automatically by the action of the lever, W, and its connections, and the reciprocating shaping head is drawn farther forward than the table and consequently away from the centers for holding the work. The work is then inserted between the centers and secured thereto in the usual and well known manner, not necessary to be described. The operator then moves the table, G, toward the cutters, C, by means of the lever, 5, and the work may be fed by the same means or by other suitable means usually applied to lathes of this class. In moving the table, G, toward the cutters, C, the cutters, I, are moved on the table toward the work or stick to be turned or shaped. 35 At the same time the lever, W, throws in gear the cam-shaft, 3, and driving center which then rotate in unison. The cams B' and B'' which are attached to said cam-shaft and are shaped according to the shape to be imparted to the stick fed to the cutters operating against the shoes, H, and H' on the spring restrained centers and reciprocating cutter-head block impart a horizontal motion to the centers and a different horizontal motion to the said cutter-head. The different vibratory motions of the centers and reciprocating cutter-head cause one part of the stick to be cut to one shape and another part to be cut to another shape, or both parts may be cut to the same shape but may differ in size. The cutters on the main cutter-head opposite the supplementary cutter-head may be removed when they would hinder or interfere with shaping of the work as desired.

55 I am aware that a swinging oscillating cutting attachment has been employed to some extent for this purpose, but it is very objectionable, not only because it is complicated, cumbersome and expensive, but it is inconvenient and interferes with the removal and insertion of the work; besides, it necessitates the placing of the cam for operating the attachment on the live spindle of the lathe, instead of on a separate shaft, which relieves the work of all jar or vibration, produced when the cam is on the said live-spindle.

My improved attachment can be quickly and completely removed when not in use, takes up but little room, has fewer parts than the swinging attachment and is more simple and easily constructed and applied. A shield similar to that covering the main cutter-head may be suitably supported over the supplementary cutter-head if desired.

Having described my invention, what I claim as new, and desire to secure by Letters Patent, is—

1. The combination with a lathe for cutting irregular forms having a cam shaft separate from the live spindle and a cam on said shaft to move the work toward and from the cutter-head, of a supplementary revolving cutter-head, a supplementary cam on the cam shaft to move the supplementary cutter-head toward and from the work, a rectilinearly reciprocating block in which the latter cutter head is journaled and a bearing mounted on said block to make contact with the supplementary cam, as set forth.

2. The combination with a lathe for cutting irregular forms having a rotatable cutter-head and a reciprocating table movable toward and from the said cutter-head, of a block mounted to slide on the table toward and from the said cutter-head, a supplementary cutter-head journaled in the said block, a cam shaft, one or more cams on said shaft to move the holders of the work, a cam on said shaft to move the sliding block toward and from the work, a pulley on the shaft of the supplementary cutter-head, and means to rotate the latter cutter-head, substantially as described.

3. The combination with a lathe for cutting irregular forms having a rotatable cutter-head and a reciprocating table movable toward and from the said cutter-head, of a block mounted to slide on the table toward and from the said cutter-head, a supplementary cutter-head journaled in the said block, a cam-shaft, parallel to and below the horizontal plane of the live spindle, one or more cams on said shaft to move the holders of the work, a cam on said shaft to move the sliding block toward and from the work, a pulley on the shaft of the supplementary cutter-head, and means to rotate the latter cutter-head, substantially as described.

4. The combination of a lathe for cutting irregular forms having a rotatable cutter-head and a reciprocating table movable toward and from the said cutter-head, of a block carrying a second cutter-head and mounted to slide on the said table toward and from the first mentioned cutter-head, a cam-shaft, a cam on said shaft to move said block, means to move said table, and suitable devices connecting the frame of the lathe with the said block whereby the movement of the said table in either direction will cause the said block to move a greater distance than the table, as and for the purpose described.

5. In combination with the stationary frame

and rotary cutter-arbor mounted on bearings fixed to said frame, stationary ways on the frame at right angles to the aforesaid arbor, a feed table sliding on said ways, rotary work-holding centers mounted on said table vibratory independently thereof, a revoluble shaft journaled in bearings on said table, cams attached to said shaft and imparting vibratory motion to the aforesaid centers, a supplementary cutter arbor, a block provided with bearings in which the arbor is journaled, a base secured to said table for the block to slide on, and another cam on the shaft to vibrate the said block independently of the aforesaid centers, as set forth.

6. The combination with the arbor carrying the main cutter-heads and a feed table movable toward and from the said cutter-heads, rotary work-holding centers mounted on said table and vibratory independently thereof, a rotary shaft carried on the table, cams affixed to said shaft, and imparting vibratory motion to the aforesaid centers, a vertical rotary shaft adapted to swing with its upper end toward and from the aforesaid arbor, gears transmitting motion from the vertical shaft to the aforesaid cam-shaft and head-center, a base mounted on the table, a block provided with bearings adapted to slide on the base, an arbor carrying supplementary cutter-heads journaled in the bearings, and a cam affixed to the aforesaid cam-shaft to impart vibratory motion to the cutter-head block, as set forth.

7. In combination with the arbor carrying the cutter-heads, the feed-table movable toward and from said cutter-heads, work-holding centers mounted on said table and vibratory toward and from the cutter-heads independent of the table, a shaft mounted on said table parallel with the aforesaid arbor, cams affixed to said shaft and imparting vibratory motion to the work holding centers, a horizontal counter shaft receiving motion from the aforesaid arbor, a vertical shaft adapted to swing with its upper end toward and from the arbor, worm-gears transmitting motion from the counter shaft to the vertical shaft, a worm on the upper end of the vertical shaft, a worm-wheel on the aforesaid cam shaft meshing with the latter worm, gears transmitting motion from said cam-shaft to the work-holding driving center, a base mounted to slide parallel with the axis of the cam shaft, a block provided with bearings adapted to slide on the base toward and from the said cam-shaft, a cam affixed to the shaft to impart vibratory motion to the block, and an arbor carrying cutter-heads mounted in said bearings, as set forth.

8. In combination with the frame, the arbor carrying the cutter-heads, and the feed-table movable toward and from the cutter-heads, work-holding centers mounted on said table and vibratory independent thereof, a shaft

mounted on the same table parallel with the arbor, cams on said shaft vibrating said centers, gears transmitting motion from said shaft to the head center, a worm-wheel on the cam-shaft, a vertical arm adapted to swing with its upper end toward and from the arbor, a vertical rotary shaft journaled on said arm, a worm on said shaft adapted to engage and release the aforesaid worm-wheel, a bell-crank lever mounted on the aforesaid cam-shaft, a link connecting one arm of said lever to the upper end of the aforesaid vertical rod, a rod connecting the other arm of the bell-crank lever to the frame, a vibratory block carrying an arbor provided with a cutter-head and a pulley, an adjustable shoe on said block, and a cam on said cam-shaft adapted to rotate in contact with the said shoe, as and for the purpose set forth.

9. The combination with the frame, A, and arbor, 1, the ways, D, D, the table, G, provided with the guide, *m*, and the head-block and tail-block, each composed of a base mounted on said guide and formed with a transverse tongue, *n*, on its top, a block grooved correspondingly in its under side and mounted on said base and provided with the work-holding center, a spring forcing said block toward the arbor, a rotary shaft, 3, mounted on the table and cams on said shaft pushing the two center carrying blocks in opposition to the action of the springs, of a base mounted on said guide between the aforesaid bases and also formed with a transverse tongue on its top, a block grooved correspondingly in its under side and mounted on said base and provided with a rotatable cutter-head and pulley, a spring forcing said block toward the said arbor, and a cam on the shaft, 3, to push the cutter-head block in opposition to the action of its spring, as set forth.

10. The combination with the frame, A, and arbor, 1, the ways, D, D, the table, G, provided with the guide, *m*, and the head and tail centers, of a base mounted on said guide and formed with a transverse tongue on its top, a block grooved correspondingly in its under side and mounted on said base and provided with a rotatable cutter, means to rotate the said rotatable cutter, a spring forcing said block toward the arbor, a rotary shaft, 3, mounted on the table and a cam on said shaft to push the said block carrying the rotatable cutter in opposition to the action of the spring, as set forth.

11. In combination with the arbor, 1, feed-table, G, and cam-shaft 3 mounted on said table, of a supplementary cutting attachment composed of the base, M, secured to said table, the vibrating block, N, mounted on the base, the rotatable cutter-head mounted on the vibrating block, and a pull-rod on the cutter-head shaft, as set forth.

12. In combination with the arbor, 1, feed-table, G, and cam-shaft, 3, mounted on said

table, of a supplementary cutting attachment
composed of the base, M, secured to said table,
the vibrating block, N, mounted to slide on
the base, the rotatable cutter-head mounted
5 on the vibrating block, the pulley, I'', shaft,
6, the support, w, fixed on said shaft, lever, v',
connected with the support, a slotted lever,
v'', pivoted to the block, N, and provided with
an adjusting screw, a lever, v, pivoted to the

base, M, and connected with the lever, v', and 10
suitable means to move the table, as set forth.

In testimony whereof I have hereunto
signed my name.

LOUIS G. MERRITT. [L. S.]

Witnesses:

ISAAC E. MERRITT,
FRED D. MOYER.